

# ARCTIKO BBR 1400-D

true cooling specialists



## BLOOD BANK REFRIGERATOR WITH TRUE DUAL™ COOLING TECHNOLOGY |

Optimal choice for safe and reliable storage of blood. These models are MDD certified and designed with stable and reliable temperature uniformity from top to bottom.

### ▶ SAFE BLOOD STORAGE

The BBR range comes with many special features compared to a standard pharmaceutical refrigerator.

To meet the strict requirements of the MDD approval, they come with probes immersed in glycerin, extra security controller, chart recorder and secondary probes, all to preserve the integrity and traceability of the precious blood.

The BBR range comes as standard with telescopic drawer systems with lanes and dividers so that you can sort and extract the stored samples with minimum efforts – taking up less time when it really matters

### ▶ MEDICAL DEVICE

Arctiko's Blood bank refrigerator range is MDD 93/42/EEC approved and certified as class IIA.

This ensures that it is approved for storing tissue or substances that are to be introduced into the human body - it is important to note the difference of class I or class II, as class I does not meet the requirement for blood storage.

To ensure maximum safety this blood bank is equipped with two controllers and a chart recorder that constantly monitors the temperature.

### ▶ OPTIMIZED INTERIOR

The valuable blood is well protected and monitored in our blood banks, ensuring the high quality of your blood bags at all times.

Insulated double pane glass doors will prevent condensation and ensures great temperature uniformity.

Together with the smart design, glass door and the telescopic drawers in Arctiko's BBR range you are ensured to have maximum capacity of blood bag, a great access and overview of the stored samples and still keeping the blood safe.



TRUE DUAL™ TECHNOLOGY

BBR1400-D

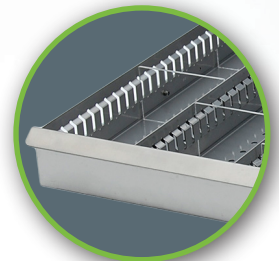

Telescopic drawer systems with lanes and dividers so you can sort and extract the stored samples with minimum efforts.



FORCED AIR COOLING



MEDICAL DEVICE CLASS IIA



Arctiko's Blood bank refrigerator range is MDD 93/42/EEC approved and certified as class IIA



The BBR range comes with probes immersed in glycerin, extra security controller, chart recorder and secondary probes.

# ARCTIKO BBR 1400-D

true cooling specialists

TRUE DUAL™ TECHNOLOGY

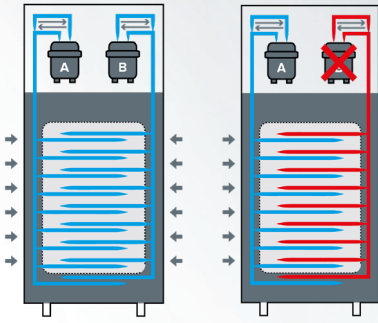

► In case of a failure, the TRUE DUAL™ technology maintains a stable temperature of +4 °C and protects the blood.

OPTIONAL FEATURES

The ARCTIKO BBR 1400-D model supports following optional features:

- GSM alarm module
- Modbus adapter
- Voltage stabilizer
- Voltage converters

MAIN DIMENSIONS

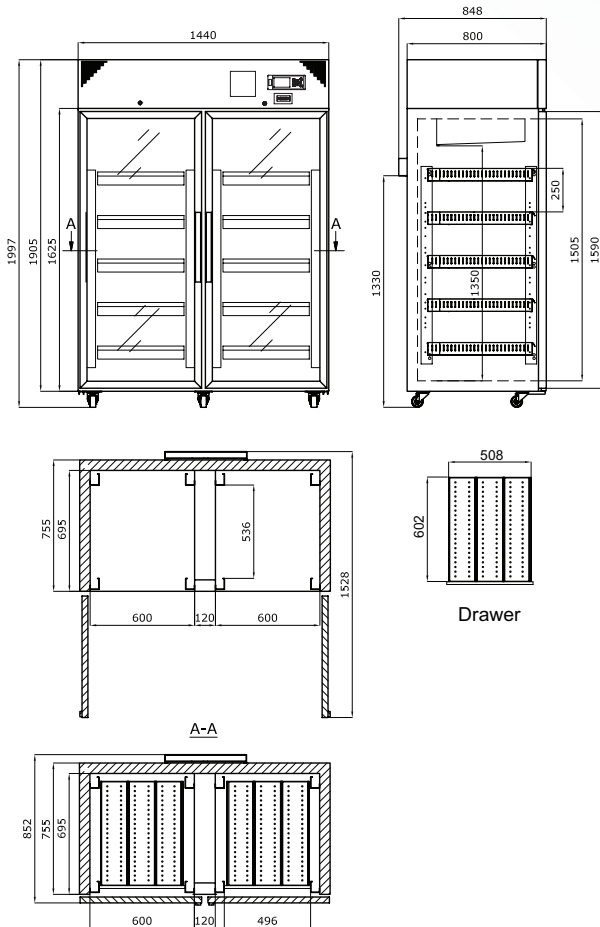

CERTIFICATES



Arctiko A/S ■ Oddeundvej 39 · DK-6715 Esbjerg N  
Phone: +45 7020 0328 ■ info@arctiko.com ■ arctiko.com

MODEL		BBR 1400-D
Main specifications	Item code	DAI 1155
	Temperature range (°C)	+4
	Max. ambient temperature (°C)	32
	Capacity (L)	1381
	Exterior dimensions WxDxH (mm)	1440x860x1997
	Interior dimensions WxDxH (mm)	1320x695x1505
	Weight (KG)	213
	Insulation (mm)	60
	Cooling technology	forced air
	Controller Model / probe type	G214 / PT1000
Power	Power supply (V)	230
	Frequency (Hz)	50/60
	Power consumption (kWh/24h)	10.5
	AMP (A)	4.4
	Power (Watt)	751
	Horse power (HP)	2 x 1/2
Alarm functions	Alarm display as text - not codes	yes
	Visual / acoustic alarm	yes / yes
	Power failure alarm	yes
	Adjustable high / low temperature alarm	yes / yes
	Open door alarm	yes
	Probe failure alarm	yes
	Low battery alarm	yes
	Compressor failure alarm	yes
Battery backup for alarms (approx. hrs.)	72	
Data logging & external connection	Voltage free contact for remote alarm (e.g. GSM alarm module)	yes
	Electronic data logger	yes
	RS 485 port	yes
	USB port for software update & data download	yes
Display features	Temperature chart recorder	yes
	Display type	4,3" with touch buttons
	Number of optional reference probes	2
	Password protection for turning unit on / off	yes
Other features	Temperature graph on display	yes
	Automatic defrost	yes
	Antifreeze function	no
	Vacuum release port	no
	Access port for external probe etc. (int. diameter mm)	12
	Light	yes
	Lock with key	yes
	Castors (total pcs) / castors with brake (pcs)	5 / 3
	Fixed feet (pcs) / levelling feet (pcs)	no
	Sub lids / inner doors (pcs)	no
	Reversible door(s)	yes
	Fixed shelves (pcs) / adjustable shelves (pcs)	no
	Max. no. of shelves (pcs) / recommended max. no. of shelves (pcs)	no
Max. load per shelf (kg)	no	
Adjustable drawers (pcs)	10	
Max. load per adjustable drawer (kg)	30	
Max. no. of blood bags - by standard no. of adj. drawers (pcs)	600	
Refrigeration & cabinet	Number of compressors	2
	Refrigerant	R290*
	Interior cabinet material	stainless steel
	Exterior cabinet material	painted steel
	Colour (exterior cabinet)	white
	Foam type	polyurethane
Shipping	VIP vacuum insulated panels	no
	Shipping weight (kg)	340
	Shipping dimensions WxDxH (cm)	156x108x220
Shipping volume (m <sup>3</sup> )	3.71	

Actual performance of products may vary upon various factors. All rights to this temperature mapping belong to Arctiko A/S. The drawing may not be copied nor presented to any other person without prior written consent of Arctiko A/S.